

INSTALLATION & MAINTENANCE FOR LT-SERIES ASSEMBLIES

I. OVERVIEW OF FUSIBLE LINK ASSEMBLIES

AVK Carbo-Bond fusible link valve assemblies are designed for flow shutoff protection in piping systems handling flammable gasses or liquids, solvents, toxic fluids, or any other potentially dangerous media. These fire control valves terminate flow in the event of fire, aiding in reducing fire intensity. In the event of fire, the fusible link separates, allowing the top mounted spring pack to drive an API607 fire safe rated valve into a closed position. Fusible links are available in a range of temperature settings. The fusible link valve assembly also is available in a fail open position, ideal for a sprinkler system in the event of a fire.

The fusible link assembly you have received has been assembled and tested at our factory with attention to safety in mind. AVK Carbo-Bond uses high quality materials and tested engineering to ensure that this product will operate safely and reliably. Carefully read all instructions before handling in order to avoid injury to the operator or damage to the product.

NOTE: Please refer to the attached assembly drawing FL-LT-0600 for parts identification and complete parts list.

II. GENERAL SAFETY INSTRUCTIONS

WARNING: This fusible link assembly has been shipped from the factory in the armed position and is ready for installation in line. Use extreme caution in handling the assembly because the spring pack is under full tension at all times.

For shipping purposes, the fusible link has been replaced with a safety link (#9). This part can be identified as the part that is PAINTED RED. (see illustration 2.1)

IMPORTANT: THE SAFETY LINK MUST BE REMOVED AND REPLACED WITH THE FUSIBLE LINK AFTER THE VALVE HAS BEEN PUT IN LINE. IF SAFETY LINKS ARE NOT REMOVED, FUSIBLE LINK WILL NOT OPERATE CORRECTLY.

The unit must be installed in a location with carefully maintained ambient temperatures. Installing the link in locations where high temperature fluctuations are possible (such as direct sunlight) is not recommended. Exposure to high ambient temperatures can cause the fusible links to break prematurely. (See chart 1 for link temperature ratings.)

safety link (painted red)

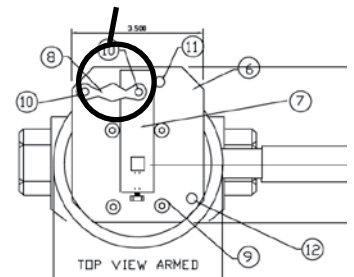

illustration 2.1

Part Number	Yield Temp.	Max. Ambient Temp.
FL-1-165	165° F / 74° C	135° F / 57° C
FL-1-212	212° F / 100° C	185° F / 82° C
FL-1-280	280° F / 138° C	253° F / 123° C
FL-1-360	360° F / 182° C	330° F / 166° C

chart 1

INSTALLATION & MAINTENANCE FOR LT-SERIES ASSEMBLIES

III. INSTALLING FUSIBLE LINKS ON THE LOW TORQUE SERIES ASSEMBLY

Please refer to the attached assembly drawing FL-LT-0600 for parts identification and complete parts list of fusible link assembly.

NOTE: THE UNIT HAS BEEN SHIPPED IN THE ARMED (OPEN) POSITION WITH A SAFETY LINK.

REQUIRED TOOLS: 1/2" and 3/4" open ended wrenches

CAUTION: SECURE VALVE IN LINE OR IN A VISE BEFORE LINK INSTALLATION

1. With 3/4" wrench, apply pressure on the retaining arm (#7) toward the open position (CCW) to relieve tension on the safety link (#8).
2. Loosen and remove 5/16" x 18 nuts on link retaining studs (#10) with 1/2" open ended wrench.
3. While maintaining pressure with 3/4" wrench, remove the safety link and replace with the fusible link supplied with the assembly. (see illustration 3.1)
4. Secure link to retaining arm (#7) studs with 5/16" x 18 nuts until link is held firmly in position. CAUTION: Do not tighten nuts. Tightening will stress the links and could result in improper functioning.
5. Release the valve handle. The unit is now properly armed.

typical fusible link



illustration 3.1

IV. OPERATION

Once the unit is properly armed, the valve may be operated closed-open in the normal manner using the valve handle (#5) without disturbing the fusible link.

V. MAINTENANCE

Refer to model number and serial number on assembly when ordering replacement parts.

IMPORTANT: The fusible link manufacturer recommends annual replacement of link(s) as part of a regular maintenance schedule. Contact your local distributor or AVK Carbo-Bond for replacement links. Order by part number or temperature rating on old link.

Replacement valve seats and seals subject to normal wear are available from your local distributor or AVK Carbo-Bond.

The spring case and declutchable gear are lifetime lubricated and do not require maintenance. Disassembly of the spring case or gear will void any written or verbal warranties.

WARNING: THE SPRING CASE CLOCKSPrING IS ALWAYS UNDER PRESSURE. DO NOT DISASSEMBLE SPRING PACK UNDER ANY CIRCUMSTANCES. DISASSEMBLY OF THE SPRING PACK COULD RESULT IN SERIOUS INJURY OR DEATH.

INSTALLATION & MAINTENANCE FOR LT-SERIES ASSEMBLIES

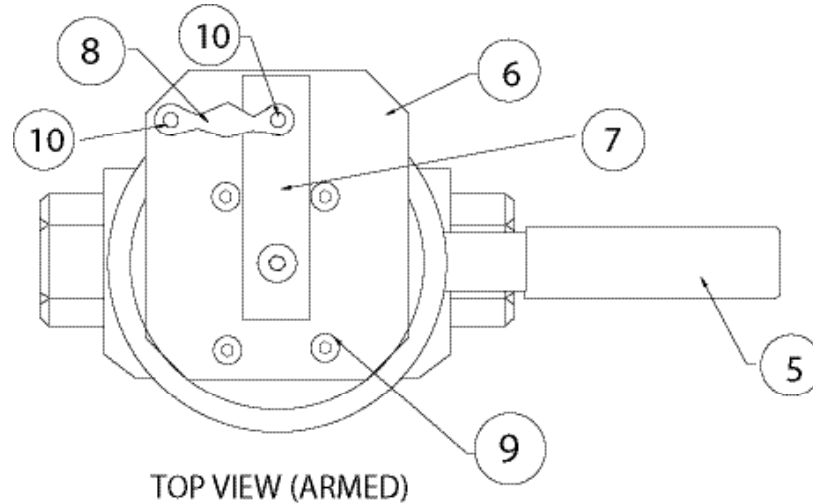

**IMPORTANT: IMPROPER
INSTALLATION OR
ARMING OF FUSIBLE
LINK ASSEMBLIES WILL
VOID WARRANTY, AS
WILL DISASSEMBLY
OF THE PRODUCT
WITHOUT PRIOR
APPROVAL FROM
FACTORY.**

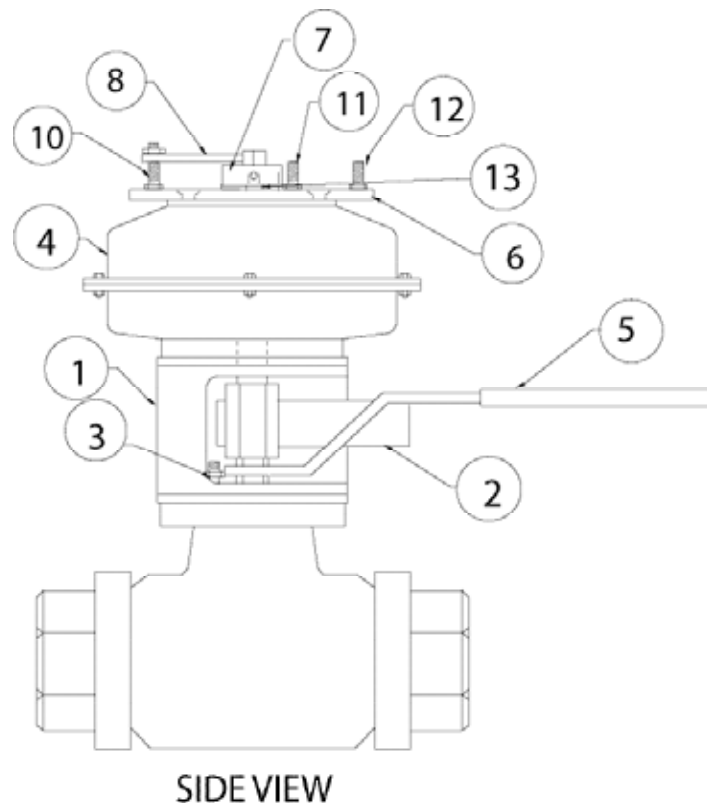

1	valve mounting bracket	7	retaining arm
2	spring closing arm	8	fusible link(s)
3	valve stop	9	mounting plate fasteners
4	spring pack (039 or 059)	10	retaining studs
5	valve handle	11	spacer/washer
6	fusible link mounting plate	12	safety link (for shipping only)

ASSEMBLY DRAWING FL-LT-0600